

**Ohio 9834 and Ohio 9816: processing tomato breeding lines with partial resistance to race T1 of bacterial spot.**

David M. Francis

Department of Horticulture and Crop Science, The Ohio State University, Ohio Agricultural Research and Development Center, 1680 Madison Ave, Wooster, OH 44691.

Sally Miller

Department of Plant Pathology, The Ohio State University, Ohio Agricultural Research and Development Center, 1680 Madison Ave, Wooster, OH 44691.

**Additional Index Words:** CIELAB, chromaticity values, disease resistance, Inbred Backcross Breeding, *Lycopersicon esculentum*

**Introduction.** Ohio 987034.1 and Ohio 981670.22 are mid season processing tomato (*Lycopersicon esculentum* Mill.) lines adapted to high population transplant culture, machine harvest, and bulk handling under humid growing environments. They are suitable parental lines for the development of hybrids used in the production of peeled, whole-canned, and diced tomato products. Both lines have been tested in plot trials the mid-western U.S. Hybrids using these lines have performed well in plot trials and in commercial scale strip trials in the mid-western and eastern U.S. and in Ontario, Canada.

**Origin.** Ohio 9816 and Ohio 9834 were trailed as 981670.22 and Ohio 987034.1, respectively. They are the products of an inbred backcross breeding program and marker assisted selection to introgress partial resistance from Hawaii 7998 into Ohio 88119 (Berry et al., 1995).

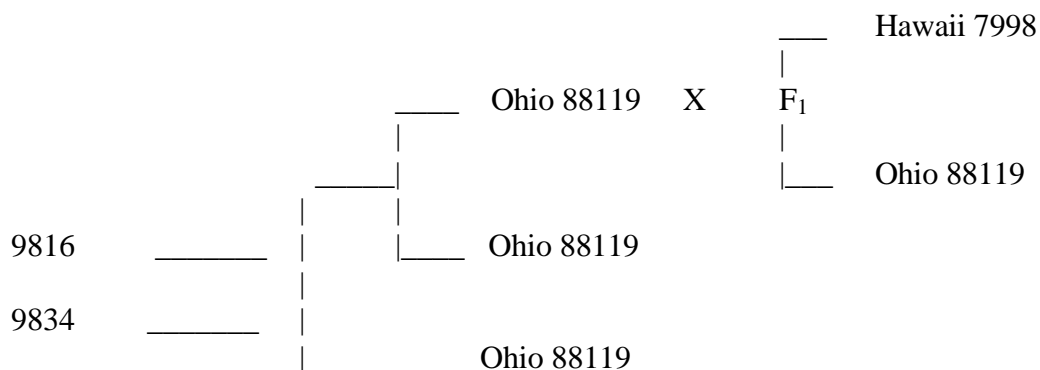

Fig. 1. Pedigree of Ohio 9816 and Ohio 9834

Presented for release Feb. 12, 2002. Approved for release \_\_\_\_\_.  
 Dr. Steven A. Slack  
 Associate Vice President for Agricultural  
 Administration & Director, OARDC

**Description.** The vines of Ohio 9834 are small to medium in size and the vines of Ohio 9816 are medium to large in size. Vines of both lines are prostrate and determinate (sp). Foliage cover is adequate for ensuring good fruit quality at maturity.

The average machine harvest yield of Ohio 9816 was 43.8 T/A over three years of testing, outperforming the major early season inbred variety Ohio 7983 and the main-season inbred variety Ohio 8245 (Table 1). Yields of Ohio 9816 are comparable to hybrid varieties (Table 1). The average machine harvest yield of Ohio 9834 was 37.9 T/A over three years of testing, comparable to other inbred varieties (Table 1). Fruit of Ohio 9816 and Ohio 9834 average 2.0 oz with two to three locules. The shape is ovate. Fruit have a small stem scar and core, are uniform ripening (u), and are attached by a jointless pedicel (j2).

The sampled raw and processed product is characterized by soluble solids content, titratable acidity, and vitamin C content that is comparable to industry standards in the midwest and eastern U.S (Table 2). The color and uniformity of color for fruit for both lines is comparable to mid-season varieties currently in use in the mid-west and eastern U.S. making these lines appropriate for the development of hybrids for peeled, whole-canned, and diced tomato products (Table 2). Evaluation of Ohio 9816 and Ohio 9834 in test crosses indicate a potential for both lines as parents for hybrid varieties (Table 3).

**Disease resistance.** Both lines have partial resistance to race T1 of bacterial spot [*Xanthomonas campestris* pv. *vesicatoria*], resistance to race 1 (*I*) of Fusarium wilt [*Fusarium oxysporum* Schlechtend. F. sp. *lycopersici* (Sacc.) Snyder and Hansen], and resistance to race 1 (*ve*) of verticillium wilt [*verticillium dahliae* Kleb]. The source of partial resistance to bacterial spot is Hawaii 7998 and genetic studies have indicated that both lines carry an introgression on chromosome five (Francis et al. in preparation). This region has been previously implicated in resistance mediated through the hypersensitive reaction and designated *Rx3* (Wang et al, 1994a and Yu et al., 1995). Our disease screening for bacterial spot emphasized field evaluation over greenhouse evaluation for resistance due to the inability of a greenhouse hypersensitive reaction to predict field performance (Somadi et al, 1994; Wang et al. 1994b). Disease evaluations were conducted in 1999, 2000, and 2001 at the Vegetable Crops Branch, Fremont Ohio. Twenty-foot plots were grown with 12 inch within plot spacing and five ft. between row spacing on standard beds. Plots were replicated three times in a randomized complete block design. Plants were inoculated with a mixture of T1 strains (110C, 118, and 89) approximately three weeks after transplant. Years and replicates within years were considered random effects in the analysis of variance. Ohio 9816 and Ohio 9834 exhibited significantly ( $p=0.0089$ ) more resistance than the parent line Ohio 88119 (Table 4). Ohio 9816 also exhibited significantly ( $p=0.05$ ) more resistance than the tolerant variety, PetoSeed 696 (Table 4) in two years of trials.

**Availability.** Material transfer agreements are available from the Office for Technology Licensing, The Ohio State University, 1960 Kenny Road, Columbus, OH 43210-1063, (614)292-3911; FAX (614)292-8907. Small samples of seed are available from the corresponding author.

## References:

- Berry, S. Z., T.S. Aldrich, K.L. Wiese, and W.D. Bash. 1995. "Ohio OX38" Hybrid Processing Tomato. Hortscience 30:159.
- Horsfall, J. G. and R. W. Barratt. 1945. An improved system for measuring plant disease. Phytopathology 36:655 (Abstr.)
- Somodi, GC, JB Jones, and JW Scott 1994. Screening tomato seedlings for resistance to bacterial spot. HortScience 29:680-682.
- Wang, JF, RE Stall and CE Vallejos, 1994a Genetic analysis of a complex hypersensitive reaction to bacterial spot in tomato. Phytopathology 84:126-132.
- Wang, J.-F., JB Jones, JW Scott and RE Stall, 1994b Several genes in *Lycopersicon esculentum* control hypersensitivity to *Xanthomonas campestris* pv. *vesicatoria*. Phytopathology 84:702-706.
- Yu, ZH, JE Wang, RE Stall and CE Vallejos, 1995 Genomic localization of tomato genes that control a hypersensitive reaction to *Xanthomonas campestris* pv. *vesicatoria* (Doidge) dye. Genetics 141:675-682.

**Acknowledgments.** Salaries and research support provided by state and federal funds appropriated to The Ohio State University, Ohio Agricultural Research and Development Center, and grant funds from the Mid-America Food Processors Association and Midwest Advanced Food Manufacturing Alliance. The mention of firm names or trade products does not imply that they are endorsed or recommended by The Ohio State University over other firms or similar products not mentioned.

<sup>1</sup> Corresponding Author. E-mail [francis.77@osu.edu](mailto:francis.77@osu.edu)

Table 1. Three year field performance data based on once-over mechanical harvesting in Fremont, OH. Yields are based on a planting density of 12,500 per acre. The disease index is a subjective score of vine health with zero indicating no apparent foliar disease and three indicating severe defoliation.

<b>Genotype</b>	<b>Yield (T/A)</b>	<b>% Ripe</b>	<b>% Green</b>	<b>% Cull</b>	<b>Weight (ounces)</b>	<b>Disease Index (0-3)</b>
7983.0	28.7	81.2	13.7	4.7	2.2	1.3
8245.0	39.0	85.2	8.9	6.1	2.2	1.3
9242.0	30.6	76.3	13.6	9.6	2.4	1.3
9816	43.8	82.9	11.5	5.7	2.0	1.1
9834	37.9	79.3	8.9	11.9	2.0	1.3
H9423	27.7	76.4	16.9	6.4	2.4	1.8
OX150	38.4	81.2	13.4	5.3	2.1	1.5
OX23	38.6	79.6	12.7	6.3	2.0	1.5
OX323	39.8	84.1	11.9	4.0	2.1	1.4
OX324	38.7	75.6	20.4	3.9	2.4	1.0
OX325	43.8	79.6	15.8	4.6	2.3	1.2
OX327	38.7	74.2	20.7	5.1	2.2	1.3
OX328	44.0	81.6	11.5	6.9	2.0	1.4
OX331	44.0	81.8	12.8	5.4	2.2	1.3
OX52	33.2	80.0	15.6	2.3	1.9	1.3
PS696	42.3	82.2	10.9	6.5	2.2	1.3
TR12	32.9	79.8	14.7	5.0	2.0	1.3
Mean	37.8	80.1	13.8	5.9	2.1	1.3
LSD (0.05)	8.3	ns	5.4	5.1	0.2	0.4
LSD (0.30)	4.2	3.6	2.8	2.7	0.1	0.2

Table 2. Three-year quality data, Multi-location trial (3 locations per year). Chromaticity values are based on the L, a, b color space with L indicating lightness to darkness; chroma, intensity; and hue, color. Color uniformity measures are based on the difference between two measurements per fruit. Low difference values indicate uniform color, or the absence of color disorders.

Genotype	Color			Color uniformity			pH	Solids	%	
	L	Chroma	Hue	Ldif	Cdif	Hdif			Crack	Force
7983.0	41.4	35.1	44.0	3.9	2.8	6.7	4.35	5.32	50	5.2
8245.0	43.4	39.0	44.0	5.1	3.1	7.4	4.34	4.96	13	5.4
9242.0	39.4	35.8	40.2	3.8	3.4	4.8	4.43	5.18	50	4.5
9816	41.3	34.7	44.4	4.0	3.0	6.1	4.39	5.03	10	4.8
9834	43.2	36.1	45.9	4.6	2.8	7.3	4.43	4.63	13	4.6
H9423	43.0	40.8	40.3	3.1	2.4	4.0	4.28	4.89	23	6.0
OX150	41.3	35.0	44.2	4.4	3.1	6.8	4.36	4.58	20	4.7
OX23	41.4	37.0	42.5	3.3	2.5	4.6	4.34	5.01	23	5.2
OX323	42.6	37.4	43.8	3.9	2.7	6.5	4.40	4.85	3	5.4
OX324	41.5	36.9	42.1	4.2	3.3	5.9	4.41	4.97	5	4.9
OX325	40.8	37.0	41.0	4.0	2.6	5.5	4.38	4.78	8	4.9
OX327	40.7	38.4	40.4	4.0	2.6	6.1	4.42	4.89	0	5.4
OX328	41.5	35.6	43.3	4.2	2.8	7.2	4.42	4.54	23	4.6
OX331	41.1	38.1	40.8	4.4	2.7	6.0	4.40	4.71	10	5.1
OX52	41.6	35.4	44.1	3.8	2.6	6.8	4.34	4.72	23	4.8
PS696	42.8	37.6	45.0	4.3	2.8	6.8	4.25	4.83	18	5.3
TR12	40.9	36.0	43.2	3.3	2.5	5.0	4.28	5.11	33	5.2
Mean	41.6	36.8	42.9	4.0	2.8	6.1	4.4	4.9	19.1	5.0
LSD (0.05)	1.7	0.9	2.5	0.8	0.4	1.7	0.07	0.30	25	0.4
LSD (0.30)	0.9	0.5	1.3	0.4	0.2	0.9	0.04	0.16	13	0.2

Table 3. Test cross evaluation from 2000 observation harvest trial, Fremont, OH.

Genotype	Tons per acre (ripe)	% Ripe	% Green	% Frt Cull	Wt (oz)	Folliea r Fruit		pH	Solids	Female	Male
						Dz. Index (0-3)	Rot Index (0-3)				
OX150	44.6	90.1	5.2	4.7	2.4	1.5	0.8	4.30	4.65	88119	9242
FG99-15	37.4	73.4	15.3	11.2	2.8	1.5	0.8	4.51	5.10	97710	9242
FG99-45	38.7	82.5	8.8	8.7	2.8	1.5	1.0	4.45	4.90	97710	E3259
OX330	49.2	87.6	4.3	8.1	2.2	2.3	1.3	4.41	3.85	981205	9242
OX336	46.7	88.5	4.3	7.2	2.4	2.0	1.0	4.41	4.35	981205	9816
FG99-19	45.4	80.5	13.7	5.7	2.5	1.0	1.0	4.34	4.90	9816	9242
OX328	44.2	74.7	19.9	5.5	2.4	1.5	0.5	4.44	3.95	9816	E3259
FG99-21	40.4	76.1	11.8	12.1	2.5	1.0	1.3	4.32	5.35	9834	9242
OX329	45.4	82.0	10.5	7.4	2.3	1.5	1.0	4.45	4.35	9834	E3259
8245	44.4	88.5	6.8	4.7	2.6	1.5	1.0	4.44	4.70		
9242	28.3	73.8	17.6	8.6	2.9	1.8	1.3	4.47	5.30		
88119	30.7	81.9	6.5	11.7	2.2	2.0	1.0	4.37	4.40		
981205	36.3	86.8	4.5	8.7	2.2	1.3	1.5	4.50	3.65		
9816	40.0	80.0	16.8	3.2	2.3	1.0	0.8	4.33	5.20		
9834	41.5	80.9	9.5	9.6	2.3	1.0	1.3	4.41	4.20		
E3259	34.2	80.4	11.6	8.0	2.4	1.8	1.0	4.42	4.40		
Mean	40.5	81.7	10.5	7.8	2.4	1.5	1.0	4.41	4.6		
LSD (0.05)	9.1	9.0	8.9	6.6	0.3	0.7	0.8	0.13	0.83		
LSD (0.30)	4.8	4.7	4.7	3.5	0.2	0.4	0.4	0.07	0.43		

Table 4. Disease ratings from field trials inoculated *Xanthomonas campestris* pv. *vesicatoria* strains 110C, 118, and 89. Ratings are based on the 1-12 Horsfall-Barratt scale (Horsfall and Barratt, 1945) with lower values indicating less disease.

Three year data		Two Year data	
Variety	Rating	Variety	Rating
Ohio 88119	7.7	Ohio 981205	8.0
Ohio E3259	5.1	Ohio 88119	7.3
Ohio 9834	4.6	Ohio 9242	6.2
Ohio 9816	4.3	PetoSeed 696	6.0
		Ohio E3259	5.7
		Ohio OX 323	5.3
		Ohio 8245	4.8
		Ohio OX 329	4.5
		Ohio OX 328	4.3
		Ohio 9834	4.2
		Ohio 9816	3.7
Mean	5.43		5.45
P	0.0089		0.0062
LSD 0.05	2.45		2.18